

THIS DRAWING IS UNPUBLISHED. RELEASED FOR PUBLICATION, 19 .  
 © COPYRIGHT 19 BY AMP INCORPORATED. ALL INTERNATIONAL RIGHTS RESERVED.

LOC	DIST	P	F	REVISIONS				
AF	50			ZONE	LTR	DESCRIPTION	DATE	APPD
					AC	NO CHNG PER 0710-0498-95	11/14/95	JR/PD

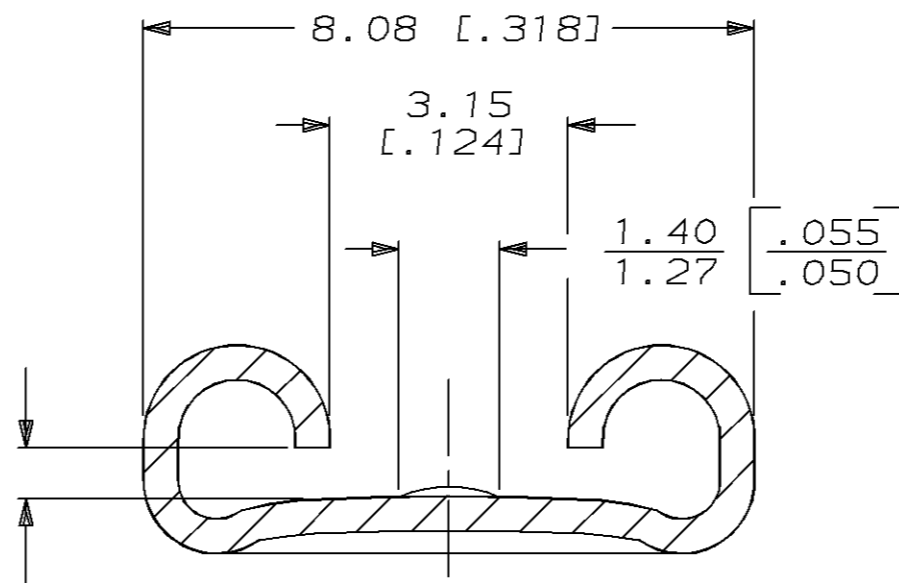
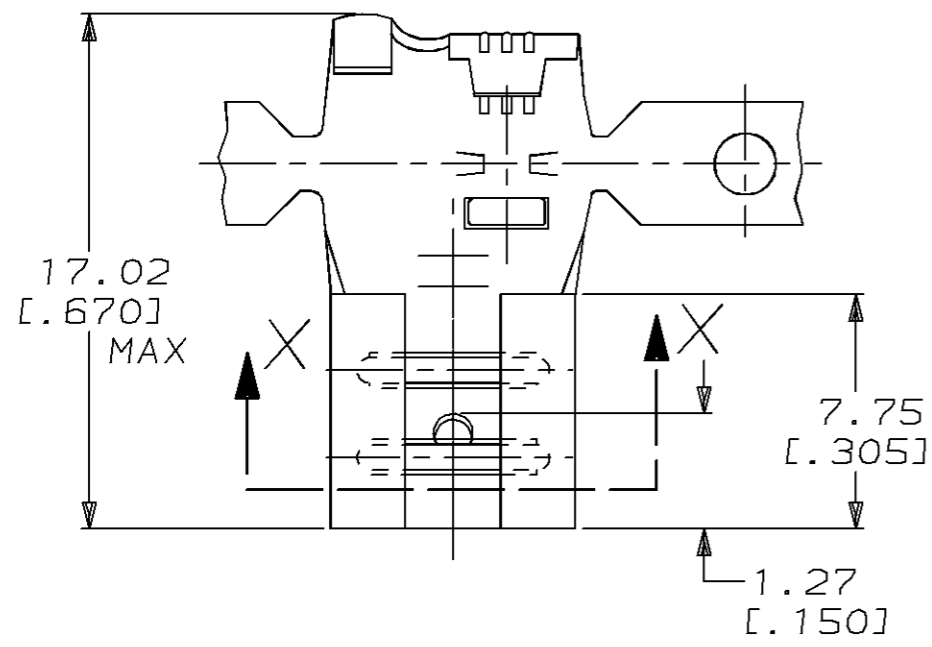

FITS 6.35 [.250] SERIES FASTON TABS  
 SECTION X-X  
 SCALE 10:1

- 1 CONTINUOUS STRIP ON REELS.
- 2 FOREIGN PRODUCTION ONLY
- 3 SILVER PL 0.00381 [.000150] MIN
- 4 TIN PL 0.002032 [.000080] MIN
- 5 NICKEL PL 0.00381 [.000150] MIN

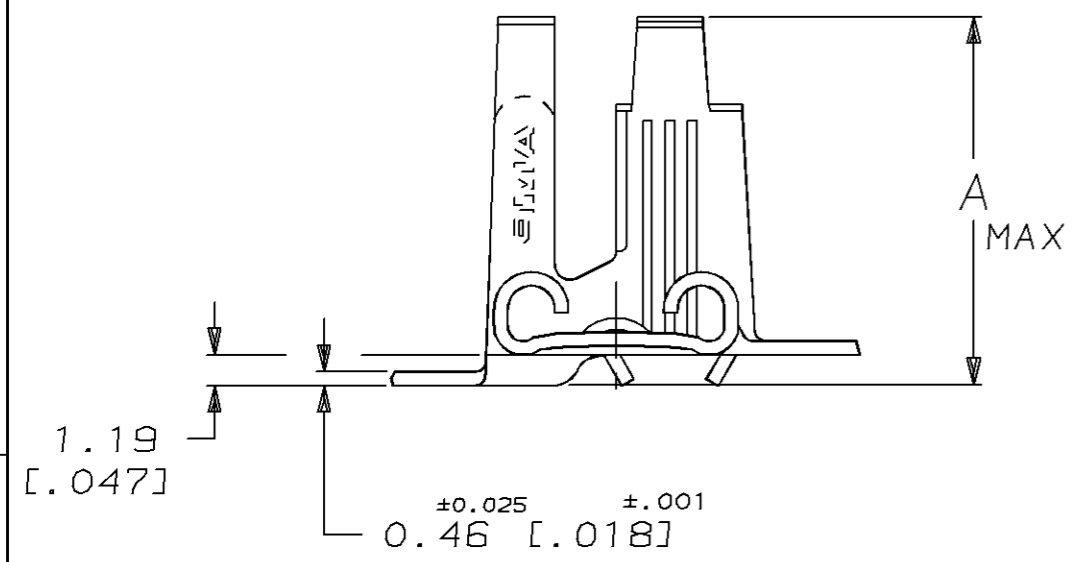

12.19 [.480]		3.0-5.0mm <sup>2</sup> [12-10] AWG 6000-10600 CMA		NICKEL 5	T2 STEEL	42563-9
				TIN 4	T3 PHOS BRZ	42563-8
				SILVER 3	T3 PHOS BRZ	42563-6
				SILVER 3	T3 PHOS BRZ	<del>42563-7</del>
				TIN 4	T3 PHOS BRZ	<del>42563-5</del>
				-	T3 PHOS BRZ	<del>42563-4</del>
				SILVER 3	#4H BRASS	<del>42563-3</del>
				TIN 4	#4H BRASS	42563-2
				-	#4H BRASS	<del>42563-1</del>
DIM A	INSULATION RANGE	WIRE RANGE	MATING TAB THK ±0.025 [.001]	FINISH	MATERIAL	PART NO
	2.79-5.33 [.110-.210] DIA	3.0-5.0mm <sup>2</sup> [12-10] AWG 9600 MAX CMA	0.813 [.032]			

**METRIC**

DO NOT SCALE PRINT. UNLESS SPECIFIED DIMENSIONS IN mm [INCHES] TOLERANCES ON:  
 2 PLC DEC ± 0.38 [.015]  
 3 PLC DEC ± -  
 ANGLES ± -  
 MATERIAL SEE TABLE  
 FINISH SEE TABLE

**AMP** AMP Incorporated  
 Harrisburg, PA 17105-3608

NAME  
 RECEPTACLE, FASTON, FLAG,  
 6.35 [.250] SERIES

SIZE	CAGE CODE	DRAWING NO
B	00779	42563
SCALE	SHEET	
4:1	1 OF 1	